

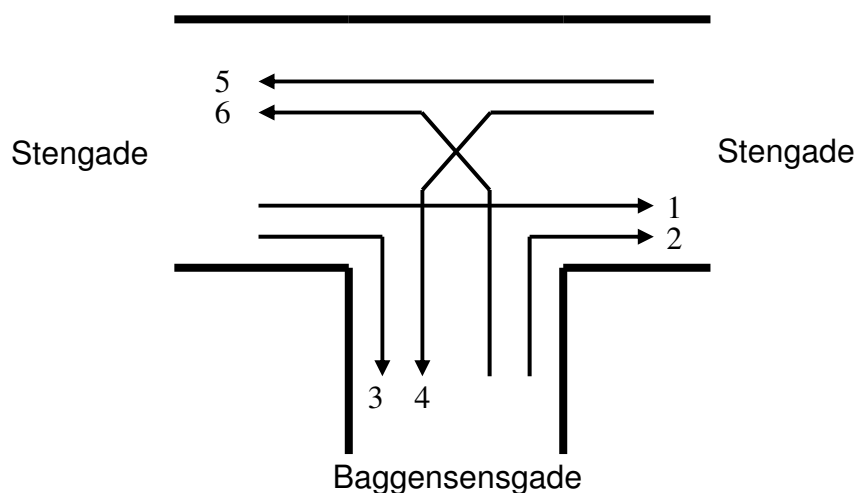

København Kommune
 Vej & Park, Trafik og Plankontoret, TPo
 Njalsgade 15, 1. sal, 2300 København S

**ANTAL KØRETØJER I KRYDSET
 STENGADE/BAGGESENSGADE
 ONSDAG D. 25. OKT. 2006**

BILAG 6



Tallene på pilene refererer til kolonnerne i nedenstående skema

Retning Kl.	1		2		3		4		5		6	
	Let Trafik	Tung Trafik	Let Trafik	Tung Trafik	Let Trafik	Tung Trafik	Let Trafik	Tung Trafik	Let Trafik	Tung Trafik	Let Trafik	Tung Trafik
06.00 - 07.00	23	8	3	0	9	0	8	2	24	10	8	1
07.00 - 08.00	45	8	5	0	11	0	5	0	59	11	15	1
08.00 - 09.00	42	18	1	0	17	0	10	0	91	17	22	1
09.00 - 10.00	35	13	4	0	14	1	27	1	55	16	15	2
10.00 - 11.00	33	11	1	0	16	1	25	1	54	11	18	1
11.00 - 12.00	41	10	0	0	22	0	15	0	46	12	18	0
12.00 - 13.00	36	10	6	0	20	0	15	1	69	13	22	4
13.00 - 14.00	41	9	8	0	29	0	25	1	73	16	24	2
14.00 - 15.00	50	9	7	2	21	0	25	0	89	14	27	3
15.00 - 16.00	52	9	3	0	26	1	36	1	129	13	27	0
16.00 - 17.00	64	10	8	0	31	0	37	0	162	14	30	1
17.00 - 18.00	63	9	9	0	23	0	31	0	111	13	21	0
06.00 - 18.00	525	124	55	2	239	3	259	7	962	160	247	16



København Kommune
 Vej & Park, Trafik og Plankontoret, TPo
 Njalsgade 15, 1. sal, 2300 København S

**ANTAL KØRETØJER I KRYDSET
 STENGADE/BAGGESENSGADE
 ONSDAG D. 25. OKT. 2006**

Retning KI.	1		2		3		4		5		6									
	Let Trafik	Tung Trafik	Let Trafik	Tung Trafik	Let Trafik	Tung Trafik	Let Trafik	Tung Trafik	Let Trafik	Tung Trafik	Let Trafik	Tung Trafik								
06.00 - 07.00					23	8	3	0	9	0			8	2			24	10	8	1
07.00 - 08.00					45	8	5	0	11	0			5	0			59	11	15	1
08.00 - 09.00					42	18	1	0	17	0			10	0			91	17	22	1
09.00 - 10.00					35	13	4	0	14	1			27	1			55	16	15	2
10.00 - 11.00					33	11	1	0	16	1			25	1			54	11	18	1
11.00 - 12.00					41	10	0	0	22	0			15	0			46	12	18	0
12.00 - 13.00					36	10	6	0	20	0			15	1			69	13	22	4
13.00 - 14.00					41	9	8	0	29	0			25	1			73	16	24	2
14.00 - 15.00					50	9	7	2	21	0			25	0			89	14	27	3
15.00 - 16.00					52	9	3	0	26	1			36	1			129	13	27	0
16.00 - 17.00					64	10	8	0	31	0			37	0			162	14	30	1
17.00 - 18.00					63	9	9	0	23	0			31	0			111	13	21	0
06.00 - 18.00					525	124	55	2	239	3			259	7			962	160	247	16



København Kommune
 Vej & Park, Trafik og Plankontoret, TPo
 Njalsgade 15, 1. sal, 2300 København S

**ANTAL KØRETØJER I KRYDSET
 STENGADE/BAGGESENSGADE
 ONSDAG D. 25. OKT. 2006**

		Klokken	6-7	7-8	8-9	9-10	10-11	11-12	12-13	13-14	14-15	15-16	16-17	17-18	6-18	
Stengade nø. for Baggesensgade	Mod kryds	Let trafik	32	64	101	82	79	61	84	98	114	165	199	142	1221	
		Tung trafik	12	11	17	17	12	12	14	17	14	14	14	14	13	167
		I alt	44	75	118	99	91	73	98	115	128	179	213	155	1388	
	Fra kryds	Let trafik	26	50	43	39	34	41	42	49	57	55	72	72	580	
		Tung trafik	8	8	18	13	11	10	10	9	11	9	10	9	126	
		I alt	34	58	61	52	45	51	52	58	68	64	82	81	706	
Baggesensgade sø. for Stengade	Mod kryds	Let trafik	11	20	23	19	19	18	28	32	34	30	38	30	302	
		Tung trafik	1	1	1	2	1	0	4	2	5	0	1	0	18	
		I alt	12	21	24	21	20	18	32	34	39	30	39	30	320	
	Fra kryds	Let trafik	17	16	27	41	41	37	35	54	46	62	68	54	498	
		Tung trafik	2	0	0	2	2	0	1	1	0	2	0	0	10	
		I alt	19	16	27	43	43	37	36	55	46	64	68	54	508	
Stengade sv. for Baggesensgade	Mod kryds	Let trafik	32	56	59	49	49	63	56	70	71	78	95	86	764	
		Tung trafik	8	8	18	14	12	10	10	9	9	10	10	9	127	
		I alt	40	64	77	63	61	73	66	79	80	88	105	95	891	
	Fra kryds	Let trafik	32	74	113	70	72	64	91	97	116	156	192	132	1209	
		Tung trafik	11	12	18	18	12	12	17	18	17	13	15	13	176	
		I alt	43	86	131	88	84	76	108	115	133	169	207	145	1385	



København Kommune
 Vej & Park, Trafik og Plankontoret, TPo
 Njalsgade 15, 1. sal, 2300 København S

**ANTAL KØRETØJER I KRYDSET
 KORSGADE/STENGADE
 ONSDAG D. 25. OKT. 2006**

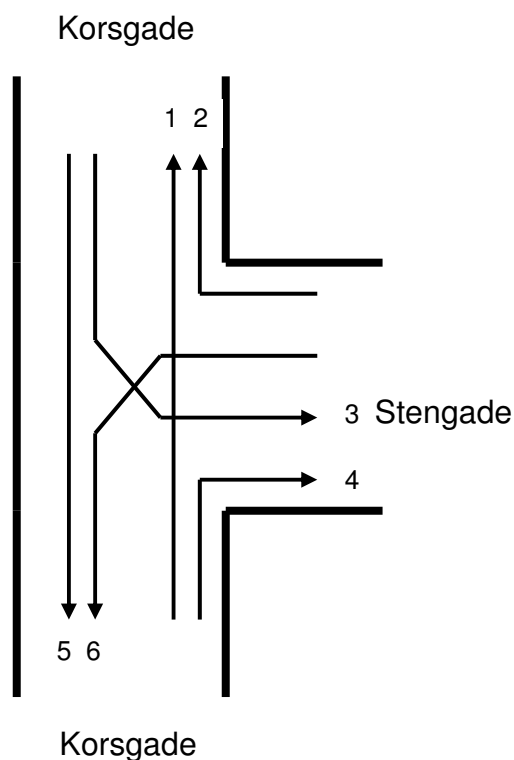

Tallene på pilene refererer til kolonnerne i nedenstående skema

Retning Kl.	1		2		3		4		5		6	
	Let Trafik	Tung Trafik	Let Trafik	Tung Trafik	Let Trafik	Tung Trafik	Let Trafik	Tung Trafik	Let Trafik	Tung Trafik	Let Trafik	Tung Trafik
06.00 - 07.00	1	0	17	11	14	7	10	0	5	0	12	1
07.00 - 08.00	2	0	66	10	24	11	28	0	6	0	12	0
08.00 - 09.00	8	2	104	12	44	11	25	0	8	1	14	0
09.00 - 10.00	11	2	58	14	33	10	22	5	7	0	18	1
10.00 - 11.00	11	2	55	12	29	12	23	2	9	1	20	1
11.00 - 12.00	9	2	45	11	39	10	22	4	6	2	20	1
12.00 - 13.00	13	1	70	12	35	9	19	2	5	0	21	0
13.00 - 14.00	17	0	85	9	50	10	27	1	7	0	26	0
14.00 - 15.00	8	1	101	9	47	10	23	0	2	0	23	0
15.00 - 16.00	10	0	129	14	54	13	22	3	5	0	25	2
16.00 - 17.00	19	4	165	18	58	13	37	1	7	0	28	0
17.00 - 18.00	19	1	116	11	57	9	31	1	6	0	20	0
06.00 - 18.00	128	15	1011	143	484	125	289	19	73	4	239	6



København Kommune
 Vej & Park, Trafik og Plankontoret, TPo
 Njalsgade 15, 1. sal, 2300 København S

**ANTAL KØRETØJER I KRYDSET
 KORSGADE/STENGADE
 ONSDAG D. 25. OKT. 2006**

Retning KI.	1		2		3		4		5		6													
	Let Trafik	Tung Trafik	Let Trafik	Tung Trafik	Let Trafik	Tung Trafik	Let Trafik	Tung Trafik	Let Trafik	Tung Trafik	Let Trafik	Tung Trafik	Let Trafik	Tung Trafik	Let Trafik	Tung Trafik	Let Trafik	Tung Trafik	Let Trafik	Tung Trafik	Let Trafik	Tung Trafik		
06.00 - 07.00			1	0	17	11	14	7			10	0			5	0	12	1						
07.00 - 08.00			2	0	66	10	24	11			28	0			6	0	12	0						
08.00 - 09.00			8	2	104	12	44	11			25	0			8	1	14	0						
09.00 - 10.00			11	2	58	14	33	10			22	5			7	0	18	1						
10.00 - 11.00			11	2	55	12	29	12			23	2			9	1	20	1						
11.00 - 12.00			9	2	45	11	39	10			22	4			6	2	20	1						
12.00 - 13.00			13	1	70	12	35	9			19	2			5	0	21	0						
13.00 - 14.00			17	0	85	9	50	10			27	1			7	0	26	0						
14.00 - 15.00			8	1	101	9	47	10			23	0			2	0	23	0						
15.00 - 16.00			10	0	129	14	54	13			22	3			5	0	25	2						
16.00 - 17.00			19	4	165	18	58	13			37	1			7	0	28	0						
17.00 - 18.00			19	1	116	11	57	9			31	1			6	0	20	0						
06.00 - 18.00			128	15	1011	143	484	125			289	19			73	4	239	6						



København Kommune
 Vej & Park, Trafik og Plankontoret, TPo
 Njalsgade 15, 1. sal, 2300 København S

**ANTAL KØRETØJER I KRYDSET
 KORSGADE/STENGADE
 ONSDAG D. 25. OKT. 2006**

		Klokken	6-7	7-8	8-9	9-10	10-11	11-12	12-13	13-14	14-15	15-16	16-17	17-18	6-18
Korsgade nv. for Stengade	Mod kryds	Let trafik	19	30	52	40	38	45	40	57	49	59	65	63	557
		Tung trafik	7	11	12	10	13	12	9	10	10	13	13	9	129
		I alt	26	41	64	50	51	57	49	67	59	72	78	72	686
	Fra kryds	Let trafik	18	68	112	69	66	54	83	102	109	139	184	135	1139
		Tung trafik	11	10	14	16	14	13	13	9	10	14	22	12	158
		I alt	29	78	126	85	80	67	96	111	119	153	206	147	1297
Stengade nø. for Korsgade	Mod kryds	Let trafik	29	78	118	76	75	65	91	111	124	154	193	136	1250
		Tung trafik	12	10	12	15	13	12	12	9	9	16	18	11	149
		I alt	41	88	130	91	88	77	103	120	133	170	211	147	1399
	Fra kryds	Let trafik	24	52	69	55	52	61	54	77	70	76	95	88	773
		Tung trafik	7	11	11	15	14	14	11	11	10	16	14	10	144
		I alt	31	63	80	70	66	75	65	88	80	92	109	98	917
Korsgade sø. f. Stengade	Mod kryds	Let trafik	11	30	33	33	34	31	32	44	31	32	56	50	417
		Tung trafik	0	0	2	7	4	6	3	1	1	3	5	2	34
		I alt	11	30	35	40	38	37	35	45	32	35	61	52	451
	Fra kryds	Let trafik	17	18	22	25	29	26	26	33	25	30	35	26	312
		Tung trafik	1	0	1	1	2	3	0	0	0	2	0	0	10
		I alt	18	18	23	26	31	29	26	33	25	32	35	26	322



København Kommune
 Vej & Park, Trafik og Plankontoret, TPo
 Njalsgade 15, 1. sal, 2300 København S

**ANTAL CYKLER I STENGADE ØST FOR PRINS JØRGENS GADE
 SAMT ANTAL FODGÆNGERE OVER STENGADE VED PRINS JØRGENS GADE
 ONSDAG D. 25. OKT. 2006**

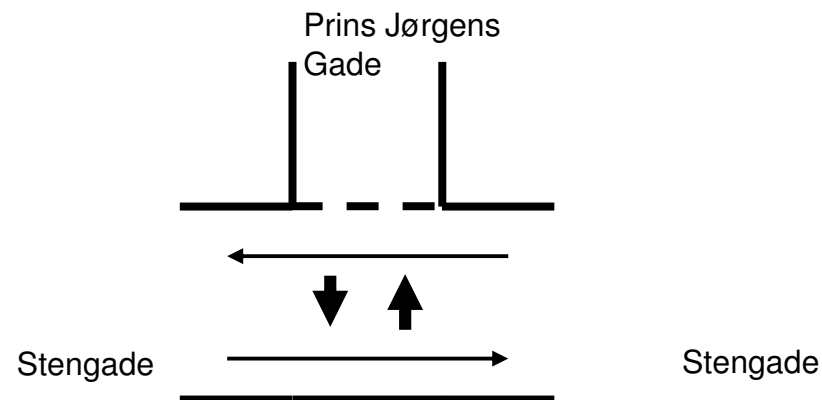

TÆLLESTED NR.	STENGADE UD FOR PRINS JØRGENS GADE										ONSDAG D. 25. OKT. 2006			
	6-18	%	6-7	7-8	8-9	9-10	10-11	11-12	12-13	13-14	14-15	15-16	16-17	17-18
CYKLER M. NØRREBROGADE	2966	50,6	96	381	558	315	174	132	138	144	183	300	265	280
CYKLER M. KORSGADE	2886	49,4	46	229	331	170	95	129	150	157	257	450	498	374
I ALT	5852	100,0	142	610	889	485	269	261	288	301	440	750	763	654
	6-18	%	6-7	7-8	8-9	9-10	10-11	11-12	12-13	13-14	14-15	15-16	16-17	17-18
FODG. MOD PRINS JØRGENS GADE	292	53,1	3	30	10	39	42	12	20	20	17	38	43	18
FODG. FRA PRINS JØRGENS GADE	305	46,9	5	7	23	33	20	13	22	17	16	29	68	52
I ALT	597	100,0	8	37	33	72	62	25	42	37	33	67	111	70

VEJRET:

TØRVEJR OG SOL