

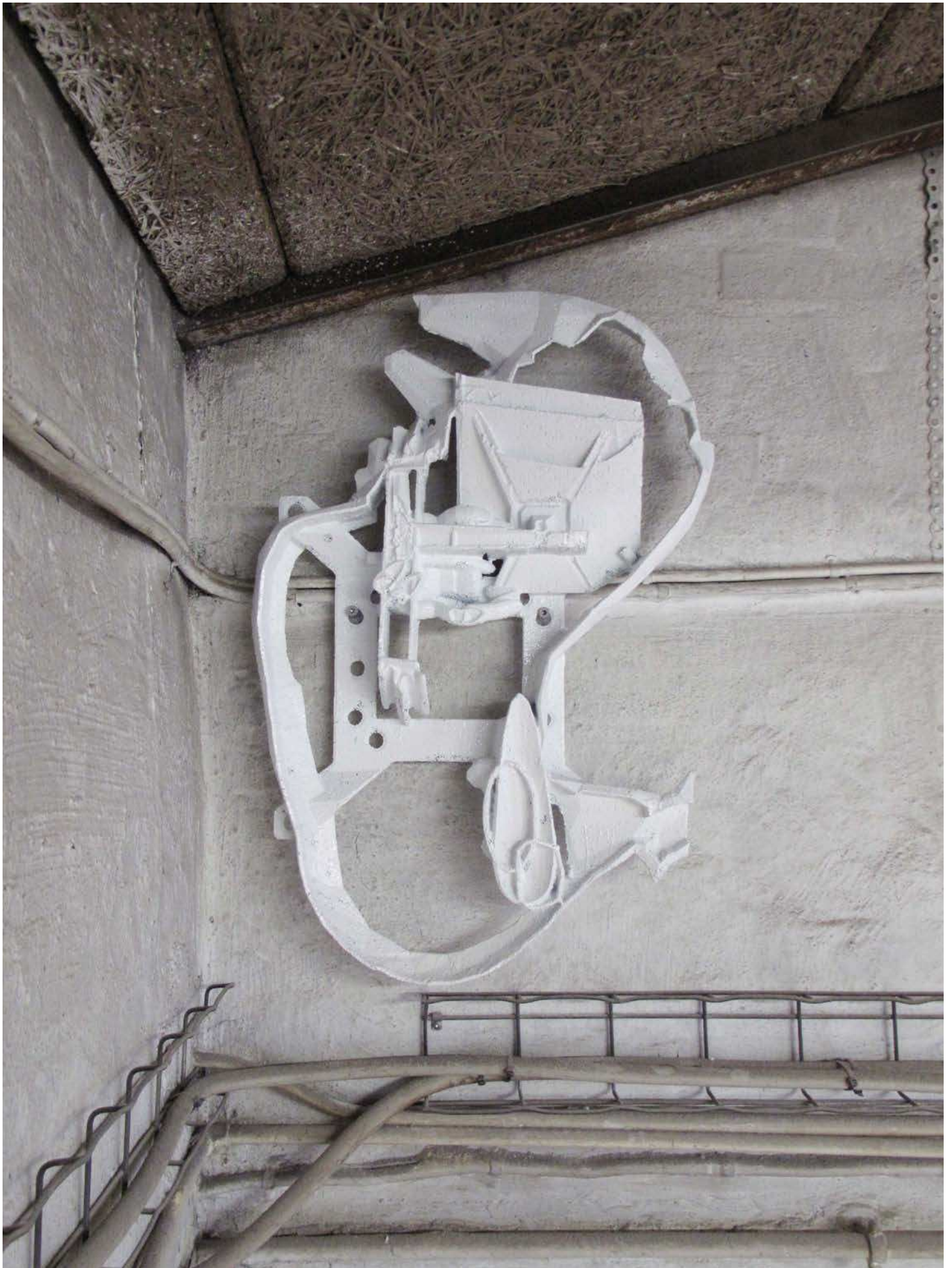

Untitled: Jockey, 2023

Aluminium, Cire Perdue støbning af CNC-fræsning
80 x 60 cm



Untitled: Monitor (arm), 2023

Aluminium (pulverlakeret), Cire Perdue støbning af CNC-fræsning
80 x 50 cm

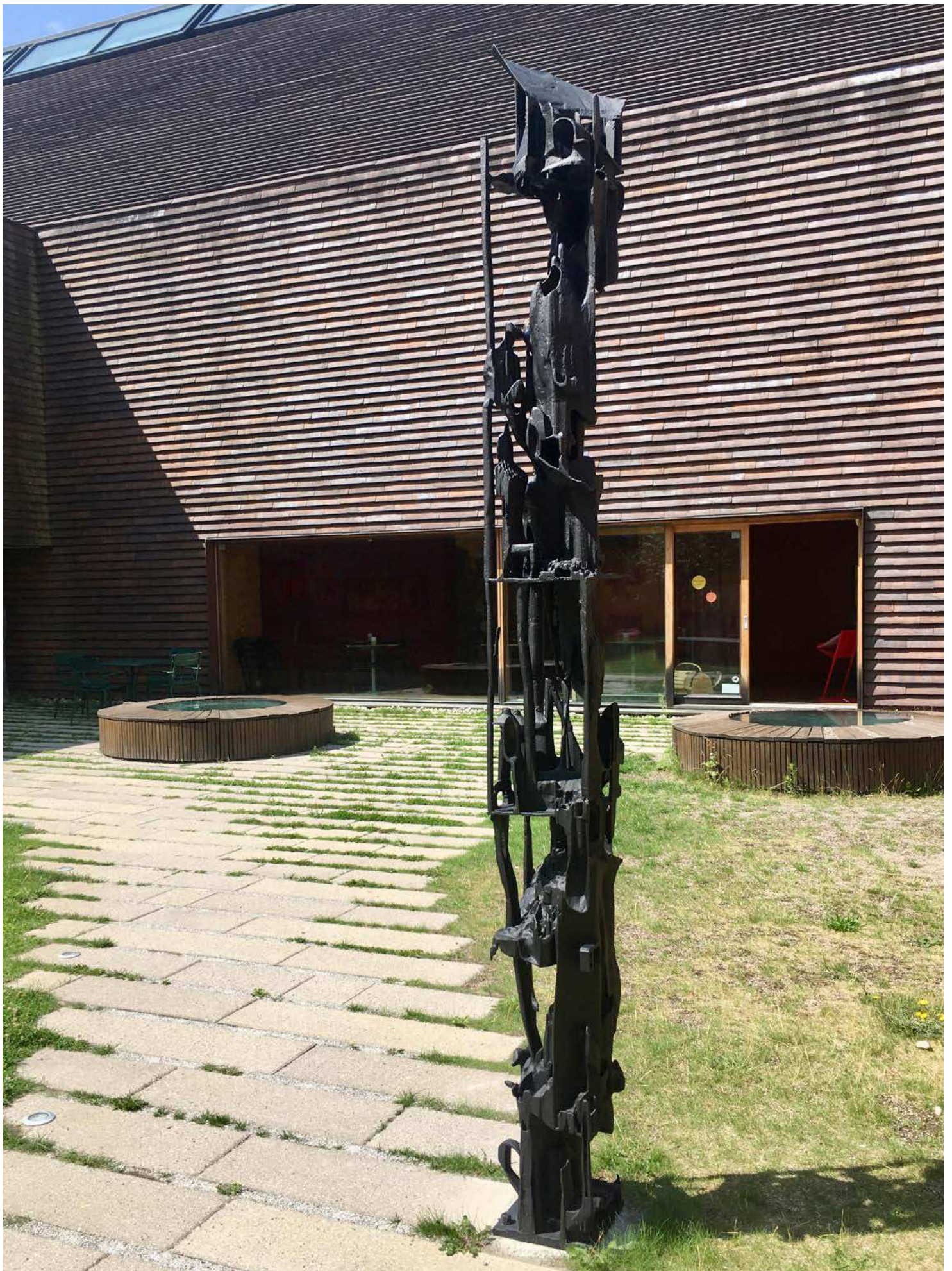

Artefact (error): A biotope based on humans' actions and doubts #2, 2023
Aluminium (Pulverlakeret), Cire Perdue støbning af CNC-fræsning
27 x 27 x 300 cm,
Sorø Kunstmuseum



Dipsacus (thirst) - A biotope based on humans' actions and doubts, 2022
Aluminium (patineret), Cire Perdue støbning af 3D-print, legablok
15 x 15 x 210 cm
A_Art_Project - Augustenborg



Dipsacus (thirst)- A biotope based on human interaction and doubt, 2022
Aluminium (patineret) Cire Perdue støbning af 3D-print, legablok
15 x 15 x 210 cm
A_Art_Project - Augustenborg



1



2



3

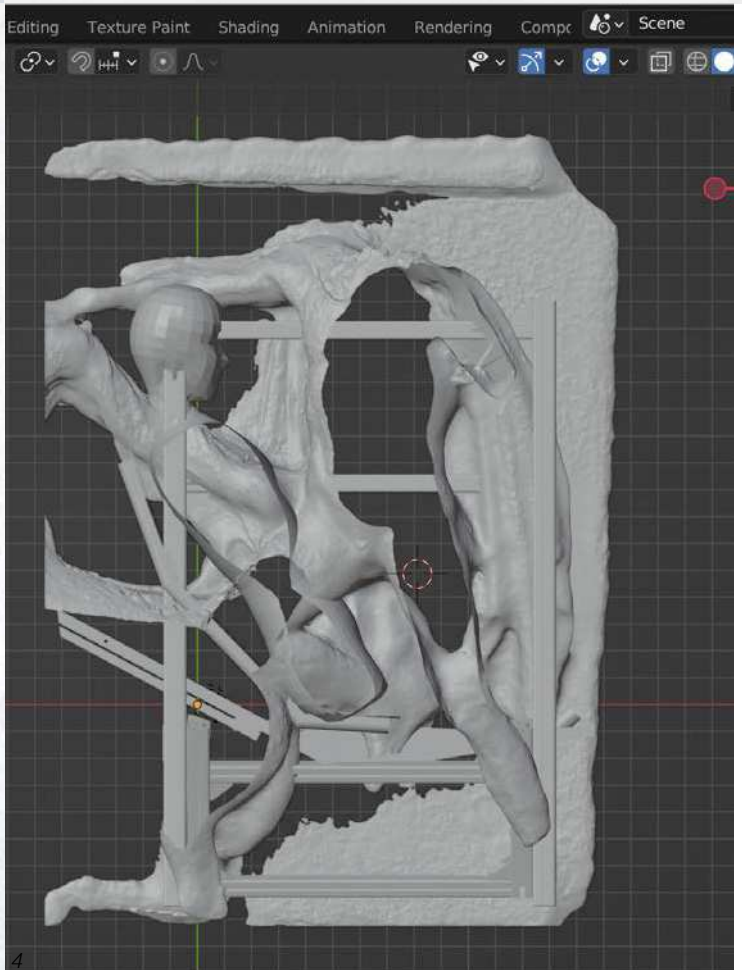

4

Untitled: Screenshot, 2022 (udsnit af serie)

1: pulverlakeret aluminium, 2: patineret aluminium, 3: bronze, 4: færdig skitse til 3D-print

Cire Perdue støbning af 3D-print

21 x 29 x 2,5 cm

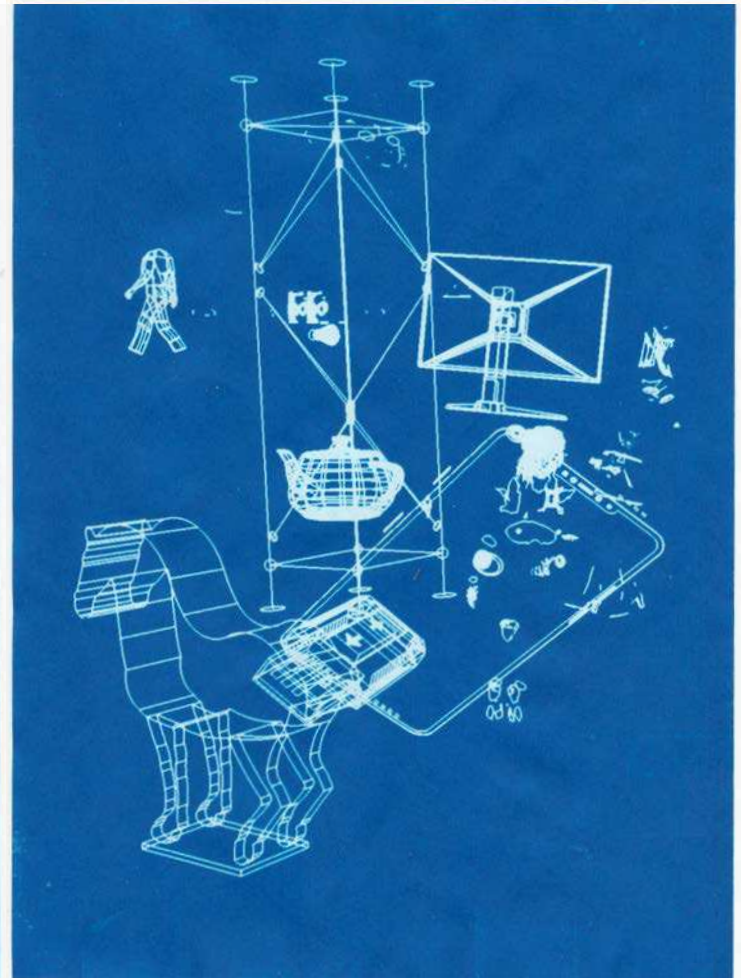
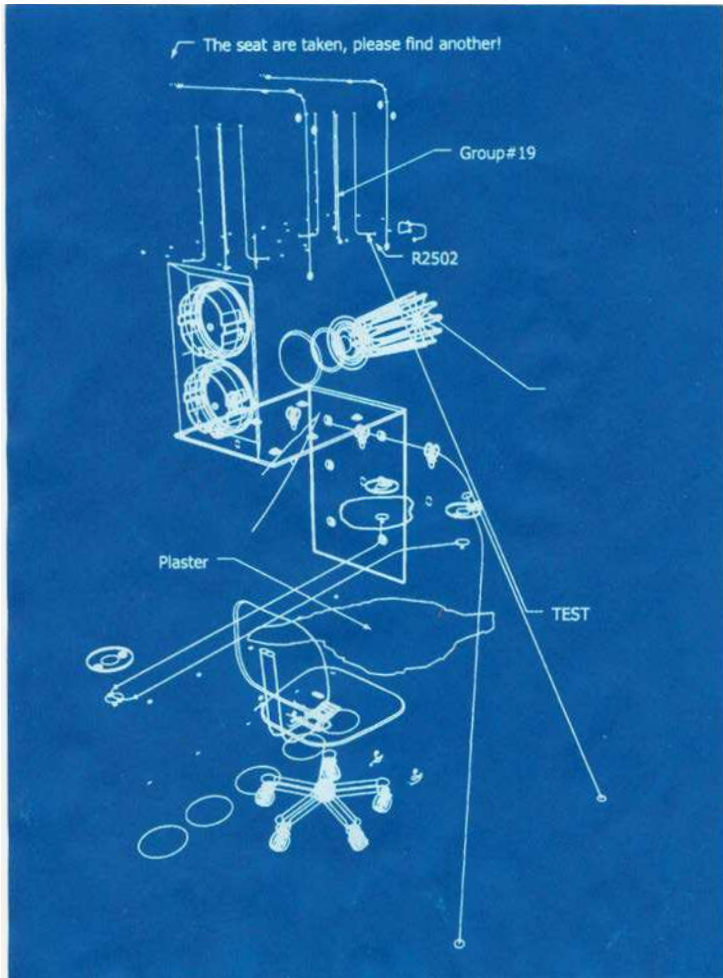
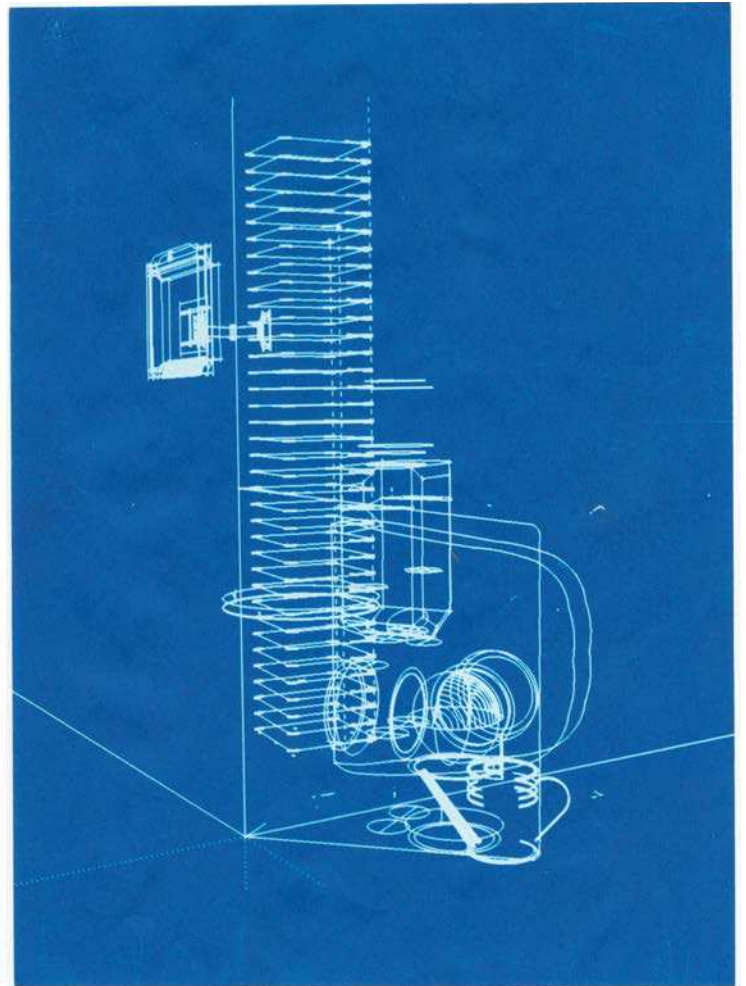
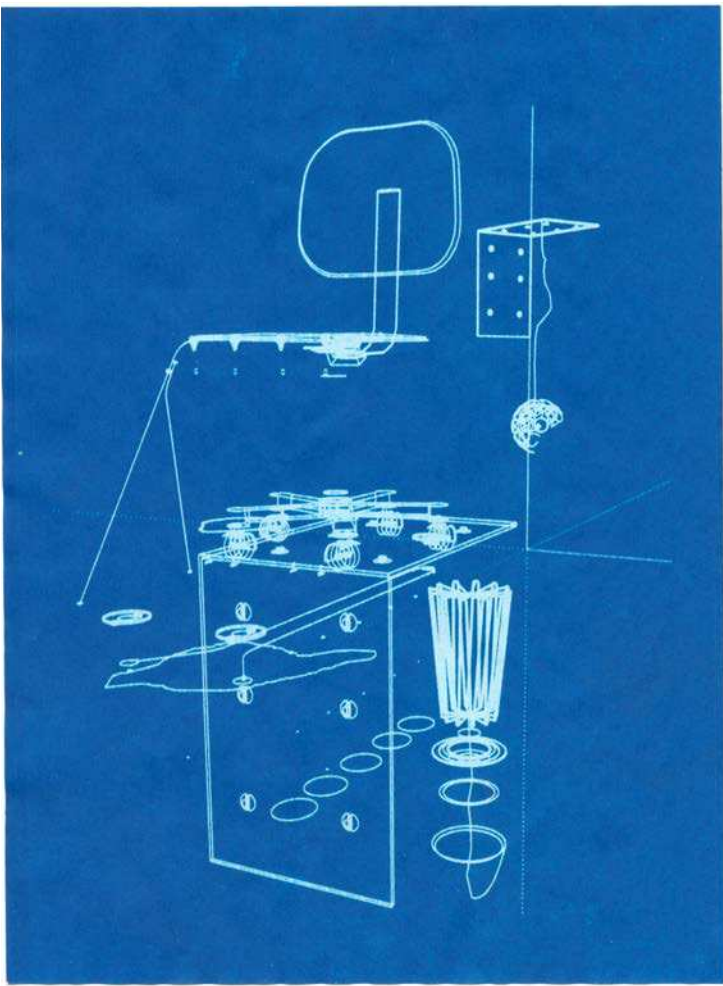

Uden titel: Screenshot, 2021 - (udsnit af serie) ongoing
Cyantopi-tryk
20 x14 cm



Untitled: Screenshot (1320x2128 pixel) - (1320x3189 pixel), 2021
Vævning (digital jacquard), uld, aluminiumsramme
Of Gardens - Regstruplund, Jyderup



90.72 Plastisk Plateau, 2018

Udsnit: flamingo relief, lysstofrør, kultegnings
20 x 300 x 600 cm,
Hvidovre Hovedbibliotek